

TECNOCAT WORK SERIES

CGB10 | CGB18

CGB10 | CGB18

WORK SERIES

CGB10 COMPATIBLE WITH: VL-GB4

CGB18 COMPATIBLE WITH: VL-GB4

WORK SERIES





VL-CGB10





VL-CGB18

CGB10 EXAMPLE

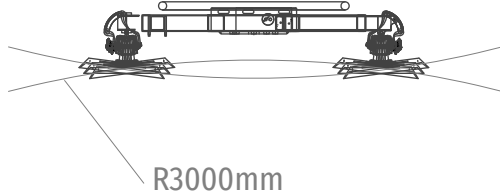
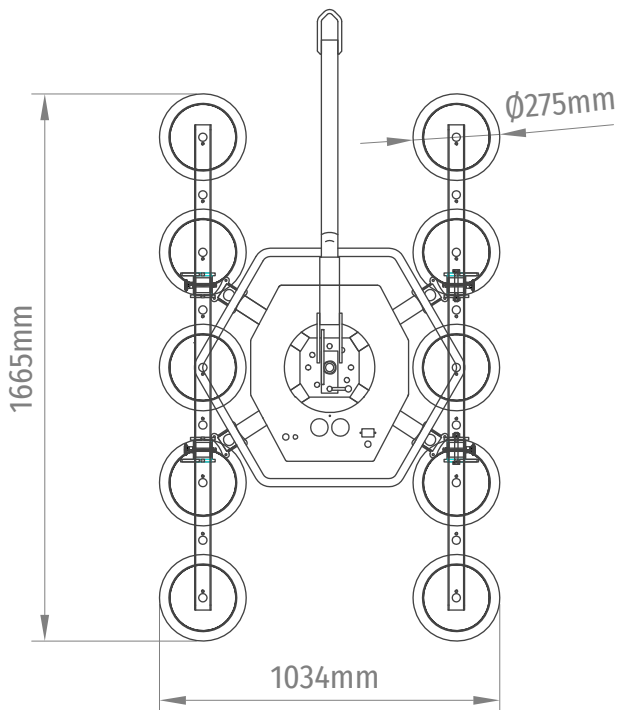
 500 kg
 OK



CGB18 EXAMPLE

 270 kg
 OK

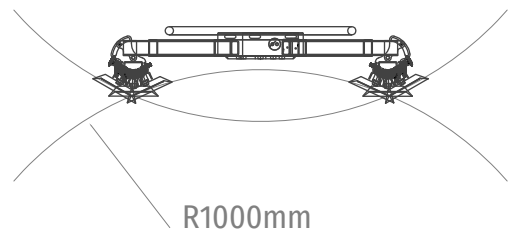
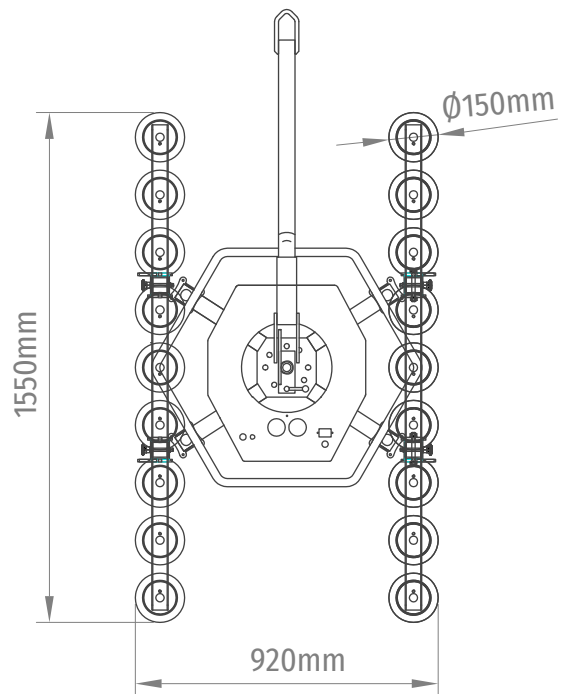

PICTOGRAMS



ELECTRICAL POWER



MANUAL ROTATION EQUIPMENT



NOMINAL ELECTRIC POWER



PNEUMATIC ROTATION EQUIPMENT



ENERGY AUTONOMY BY BATTERIES



MOTORIZED ROTATION EQUIPMENT



PNEUMATIC SUPPLY



HYDRAULIC ROTATION EQUIPMENT



MAXIMUM LOAD CAPACITY



EQUIPMENT WEIGHT



MAXIMUM LOAD CAPACITY ACCORDING EN-13155



VACUUM SYSTEM AIR FLOW



TILTING EQUIPMENT



PUSHBUTTON CABLE LENGTH



MANUALLY TILTING EQUIPMENT



WIRELESS PUSHBUTTON



PNEUMATIC TILTING EQUIPMENT



LOAD CAPACITY ACCORDING EN-13155



MOTORIZED TILTING EQUIPMENT



EQUIPMENT SUPPORT SYSTEM



HYDRAULIC TILTING EQUIPMENT



LIFTING CRANE USABLE ROTATION



ROTATION EQUIPMENT