



**TECNOCAT STORAGE**

**CLM | CLMW**

# CLM | CLMW

## STORAGE

### CLM-15



3700x2600 mm



STORAGE

### CLMW-10



3700x2600 mm



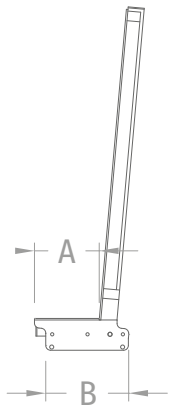

	A		B
<b>CLM-100 / CLMW-100</b>	110 mm	2000 kg	205 mm
<b>CLM-150 / CLMW-150</b>	150 mm	2500 kg	245 mm
<b>CLM-200 / CLMW-200</b>	200 mm	3500 kg	295 mm
<b>CLM-250 / CLMW-250</b>	250 mm	4500 kg	345 mm
<b>CLM-300 / CLMW-300</b>	300 mm	5500 kg	395 mm
<b>CLM-350 / CLMW-350</b>	350 mm	6500 kg	465 mm
<b>CLM-400 / CLMW-400</b>	400 mm	7500 kg	515 mm

### CLM

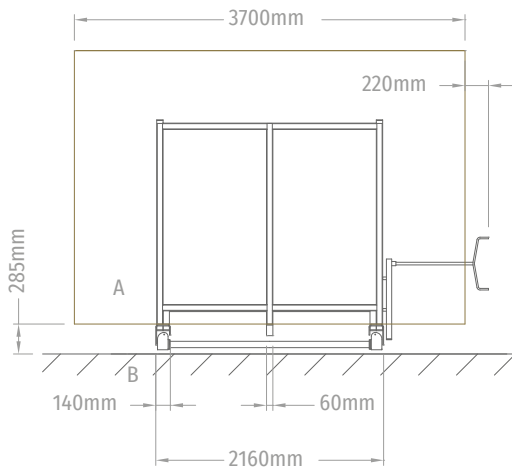

### CLMW

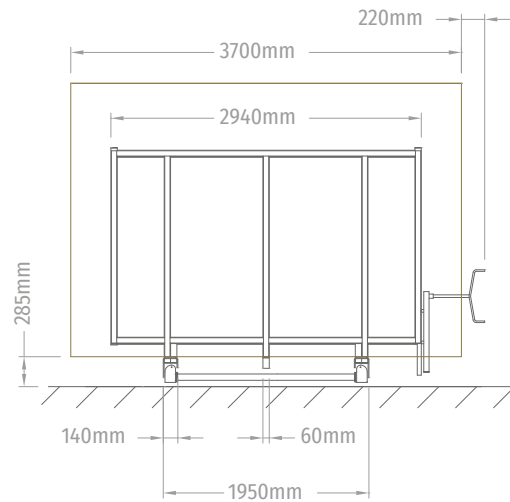

### CLM | CLMW

$$L \text{ (mm)} = \Sigma B + 850 \text{ (O)} + 150$$

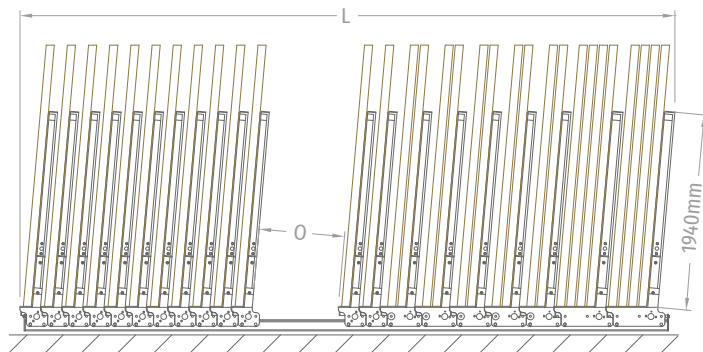

# PICTOGRAMS



ELECTRICAL POWER



MANUAL ROTATION EQUIPMENT



NOMINAL ELECTRIC POWER



PNEUMATIC ROTATION EQUIPMENT



ENERGY AUTONOMY BY BATTERIES



MOTORIZED ROTATION EQUIPMENT



PNEUMATIC SUPPLY



HYDRAULIC ROTATION EQUIPMENT



MAXIMUM LOAD CAPACITY



EQUIPMENT WEIGHT



MAXIMUM LOAD CAPACITY ACCORDING EN-13155



VACUUM SYSTEM AIR FLOW



TILTING EQUIPMENT



PUSHBUTTON CABLE LENGTH



MANUALLY TILTING EQUIPMENT



WIRELESS PUSHBUTTON



PNEUMATIC TILTING EQUIPMENT



LOAD CAPACITY ACCORDING EN-13155



MOTORIZED TILTING EQUIPMENT



EQUIPMENT SUPPORT SYSTEM



HYDRAULIC TILTING EQUIPMENT



LIFTING CRANE USABLE ROTATION



ROTATION EQUIPMENT