



TECNOCAT HANDLING

VF3-F9 | VF3-F9+4

VF3-F9 | VF3-F9+4

HANDLING

VF3-F9+4

	1300 kg
	600 kg
	230 kg



VF3-F9+4 + PRO-MESH (OPTIONAL)



HANDLING

EN4355	OK
kW	850 W
IG	—
	3 m
	OPTIONAL

	200 - 500 VAC (50 - 60 Hz) + 24 VDC
	80 L/min
	—
	—
	OK

VF3-F9

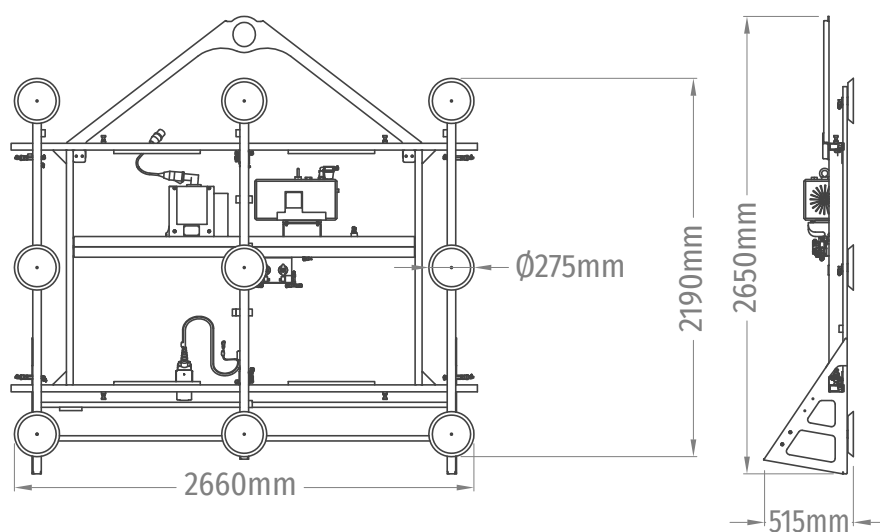

VF3-F9+4

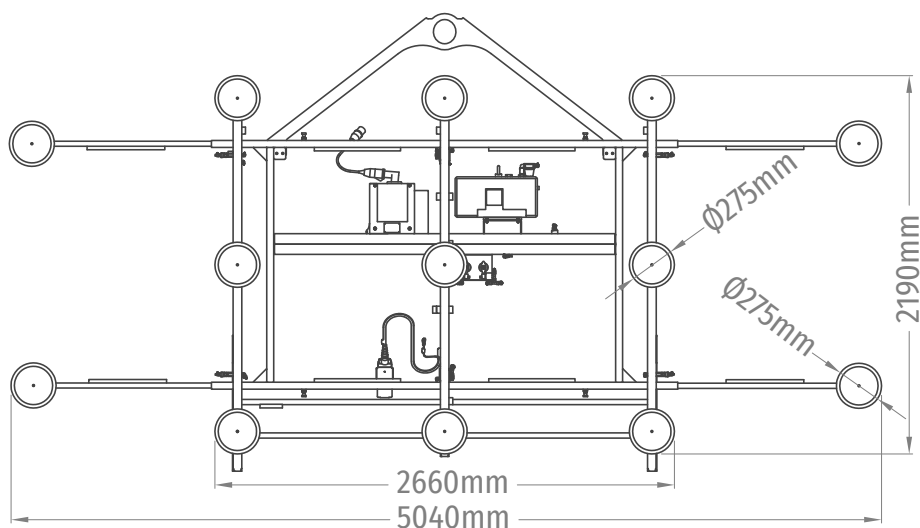

OPTIONAL

- PRO-MESH

PICTOGRAMS



ELECTRICAL POWER



MANUAL ROTATION EQUIPMENT



NOMINAL ELECTRIC POWER



PNEUMATIC ROTATION EQUIPMENT



ENERGY AUTONOMY BY BATTERIES



MOTORIZED ROTATION EQUIPMENT



PNEUMATIC SUPPLY



HYDRAULIC ROTATION EQUIPMENT



MAXIMUM LOAD CAPACITY



EQUIPMENT WEIGHT



MAXIMUM LOAD CAPACITY ACCORDING EN-13155



VACUUM SYSTEM AIR FLOW



TILTING EQUIPMENT



PUSHBUTTON CABLE LENGTH



MANUALLY TILTING EQUIPMENT



WIRELESS PUSHBUTTON



PNEUMATIC TILTING EQUIPMENT



LOAD CAPACITY ACCORDING EN-13155



MOTORIZED TILTING EQUIPMENT



EQUIPMENT SUPPORT SYSTEM



HYDRAULIC TILTING EQUIPMENT



LIFTING CRANE USABLE ROTATION



ROTATION EQUIPMENT