



**TECNOCAT** FACTORY SERIES



**VN2-GB1 | VN2-GB1+2**

# VN2-GB1 | VN2-GB1+2

FACTORY SERIES

## VN2-GB1





	250 kg
	64 kg

FACTORY SERIES

## VN2-GB1+2



	400 kg
	76 kg

<b>AIR</b>	7 bar - 100 l/min
	90° - 180° - 270° - 360°
	—

	40 L/min
	0° - 90°

## VN2-GB1

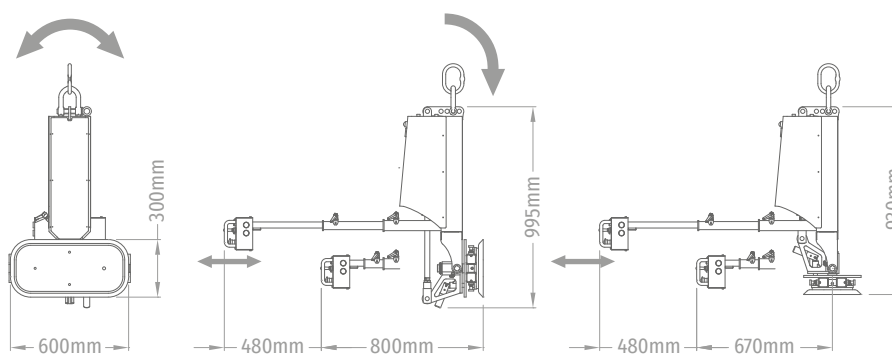

## VN2-GB1+2

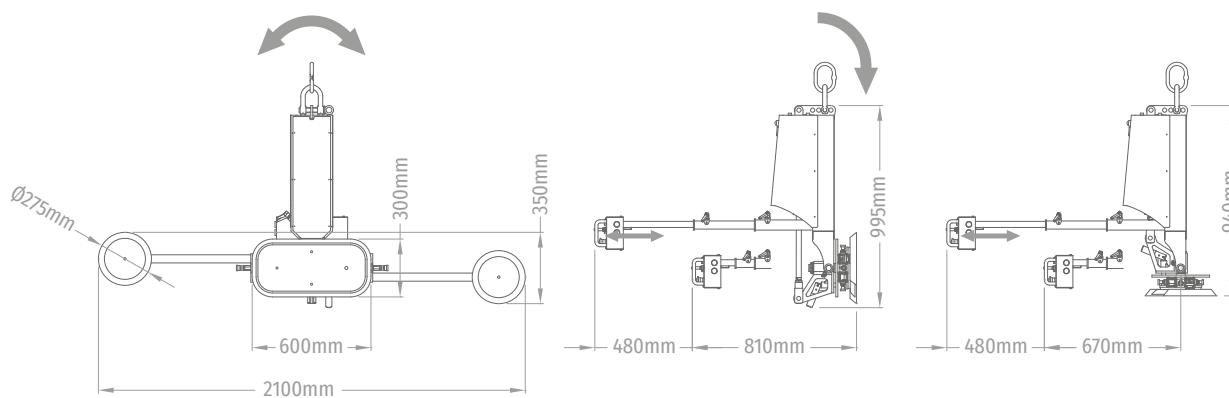

# PICTOGRAMS



ELECTRICAL POWER



NOMINAL ELECTRIC POWER



ENERGY AUTONOMY BY BATTERIES



PNEUMATIC SUPPLY



MAXIMUM LOAD CAPACITY



MAXIMUM LOAD CAPACITY ACCORDING EN-13155



TILTING EQUIPMENT



MANUALLY TILTING EQUIPMENT



PNEUMATIC TILTING EQUIPMENT



MOTORIZED TILTING EQUIPMENT



HYDRAULIC TILTING EQUIPMENT



ROTATION EQUIPMENT



MANUAL ROTATION EQUIPMENT



PNEUMATIC ROTATION EQUIPMENT



MOTORIZED ROTATION EQUIPMENT



HYDRAULIC ROTATION EQUIPMENT



EQUIPMENT WEIGHT



VACUUM SYSTEM AIR FLOW



PUSHBUTTON CABLE LENGTH



WIRELESS PUSHBUTTON



LOAD CAPACITY ACCORDING EN-13155



EQUIPMENT SUPPORT SYSTEM



LIFTING CRANE USABLE ROTATION