





TECNOCAT HANDLING

Y-16 | Y-35 | BEL

Y-16 | Y-35 | BEL



HANDLING

Y-16

	1650 kg
	25 kg



Y-35

	3500 kg
	55 kg



Y-16 + BEL-2000

Y-16

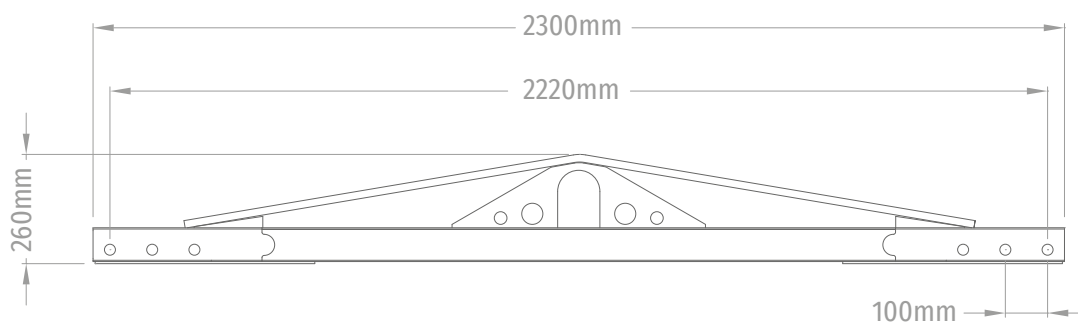

Y-35

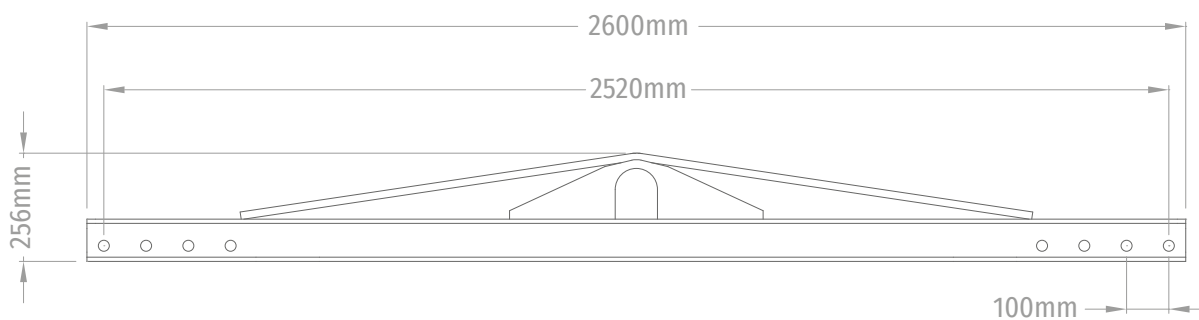

BEL-2000 | BEL-3000 | BEL-4000 | BEL-5000



BEL-2000

 2000 kg

BEL-3000

 3000 kg

BEL-4000

 4000 kg

BEL-5000

 5000 kg

PICTOGRAMS



ELECTRICAL POWER



MANUAL ROTATION EQUIPMENT



NOMINAL ELECTRIC POWER



PNEUMATIC ROTATION EQUIPMENT



ENERGY AUTONOMY BY BATTERIES



MOTORIZED ROTATION EQUIPMENT



PNEUMATIC SUPPLY



HYDRAULIC ROTATION EQUIPMENT



MAXIMUM LOAD CAPACITY



EQUIPMENT WEIGHT



MAXIMUM LOAD CAPACITY ACCORDING EN-13155



VACUUM SYSTEM AIR FLOW



TILTING EQUIPMENT



PUSHBUTTON CABLE LENGTH



MANUALLY TILTING EQUIPMENT



WIRELESS PUSHBUTTON



PNEUMATIC TILTING EQUIPMENT



LOAD CAPACITY ACCORDING EN-13155



MOTORIZED TILTING EQUIPMENT



EQUIPMENT SUPPORT SYSTEM



HYDRAULIC TILTING EQUIPMENT



LIFTING CRANE USABLE ROTATION



ROTATION EQUIPMENT