



**TECNOCAT** WORK SERIES

VL-GB4 | VL-GB4+4

# VL-GB4 | VL-GB4+4

## WORK SERIES

### VL-GB4



300 kg



45 kg

WORK SERIES

### VL-GB4+4



600 kg



65 kg

ENH3ISS	OK
	90° - 180° - 270° - 360°
	0° - 60° - 90°
	22 L/min

kW	80 W
	BATTERY CHARGE 220-240V AC 50-60 HZ
	OK - BATTERY 12V - Running period 20h aprox
	OK

## VL-GB4

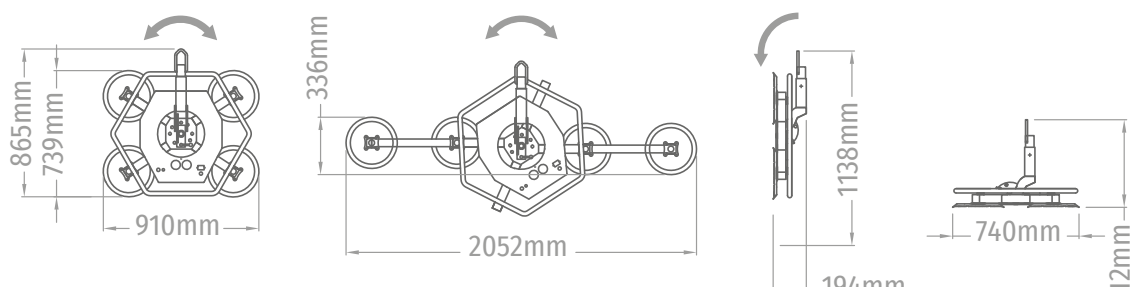

## VL-GB4+4

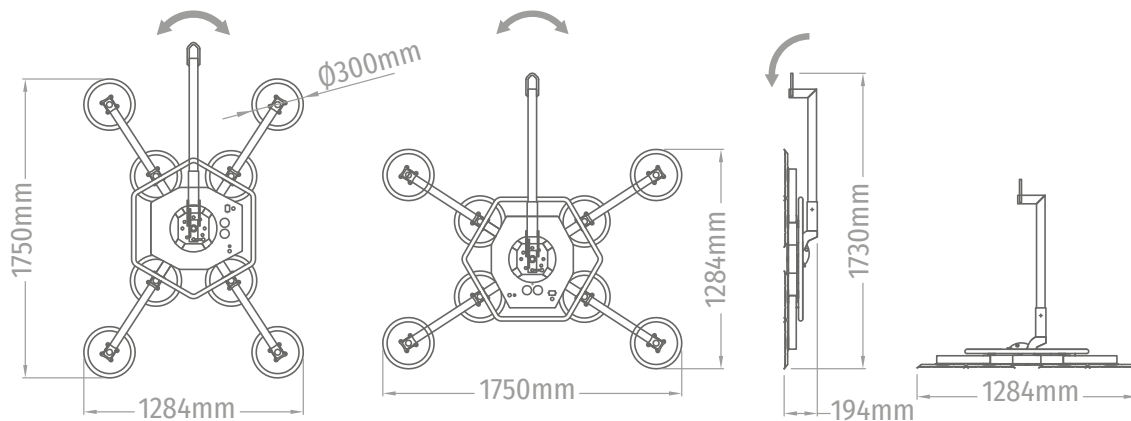

### INCLUDED

- SUPPORT WITH WHEELS
- METAL HANGING EXTENSION 2 SIZES

### OPTIONAL

- **CM-VL** METAL BOX
- **FU-P** COVERS
- HYDRAULIC PISTON
- A. CURVED ARM 9+9 CUPS Ø125 (270KG)
- B. CURVED ARM 5+5 CUPS Ø275 (500KG)

# PICTOGRAMS



ELECTRICAL POWER



MANUAL ROTATION EQUIPMENT



NOMINAL ELECTRIC POWER



PNEUMATIC ROTATION EQUIPMENT



ENERGY AUTONOMY BY BATTERIES



MOTORIZED ROTATION EQUIPMENT



PNEUMATIC SUPPLY



HYDRAULIC ROTATION EQUIPMENT



MAXIMUM LOAD CAPACITY



EQUIPMENT WEIGHT



MAXIMUM LOAD CAPACITY ACCORDING EN-13155



VACUUM SYSTEM AIR FLOW



TILTING EQUIPMENT



PUSHBUTTON CABLE LENGTH



MANUALLY TILTING EQUIPMENT



WIRELESS PUSHBUTTON



PNEUMATIC TILTING EQUIPMENT



LOAD CAPACITY ACCORDING EN-13155



MOTORIZED TILTING EQUIPMENT



EQUIPMENT SUPPORT SYSTEM



HYDRAULIC TILTING EQUIPMENT



LIFTING CRANE USABLE ROTATION



ROTATION EQUIPMENT