



TECNOCAT WORK SERIES

VL2-GB4 | VL2-GB4+2 | VL2-GB4+4

VL2-GB4 | VL2-GB4+2 | VL2-GB4+4

WORK SERIES

VL2-GB4



300 kg



50 kg



WORK SERIES

VL2-GB4+2



450 kg



57 kg



VL2-GB4+4







600 kg



64 kg



 OK
 90° - 180° - 270° - 360°
 0° - 60° - 90°
 22 L/min

 kW 80 W
 BATTERY CHARGE 220-240V AC 50-60 HZ
 OK - BATTERY 12V - Running period 20h aprox
 —

VL2-GB4

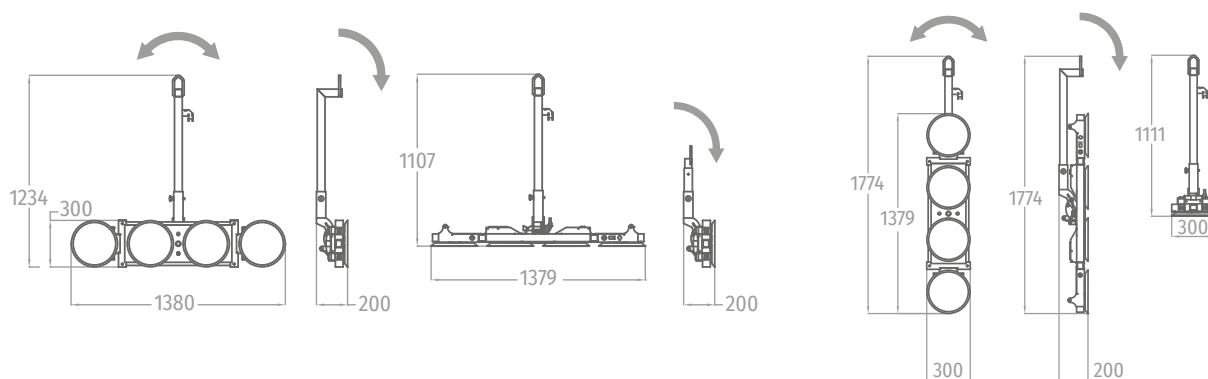

VL2-GB4+2

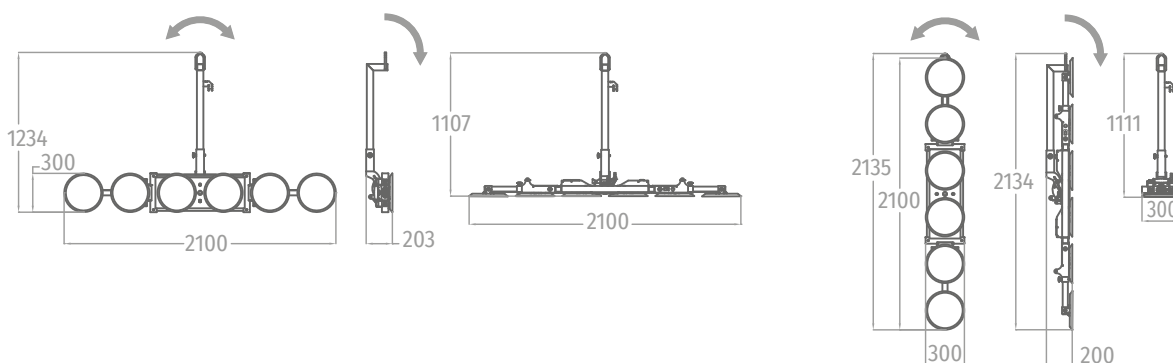

VL2-GB4+4

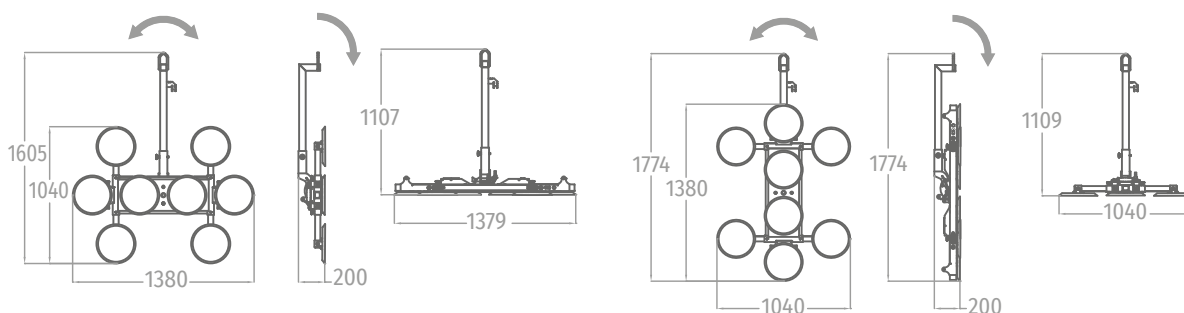

INCLUDED

- METAL HANGING EXTENSION 2 SIZES

OPTIONAL

- CM-VL2 METAL BOX
- FU-P COVERS
- HYDRAULIC PISTON

PICTOGRAMS



ELECTRICAL POWER



MANUAL ROTATION EQUIPMENT



NOMINAL ELECTRIC POWER



PNEUMATIC ROTATION EQUIPMENT



ENERGY AUTONOMY BY BATTERIES



MOTORIZED ROTATION EQUIPMENT



PNEUMATIC SUPPLY



HYDRAULIC ROTATION EQUIPMENT



MAXIMUM LOAD CAPACITY



EQUIPMENT WEIGHT



MAXIMUM LOAD CAPACITY ACCORDING EN-13155



VACUUM SYSTEM AIR FLOW



TILTING EQUIPMENT



PUSHBUTTON CABLE LENGTH



MANUALLY TILTING EQUIPMENT



WIRELESS PUSHBUTTON



PNEUMATIC TILTING EQUIPMENT



LOAD CAPACITY ACCORDING EN-13155



MOTORIZED TILTING EQUIPMENT



EQUIPMENT SUPPORT SYSTEM



HYDRAULIC TILTING EQUIPMENT



LIFTING CRANE USABLE ROTATION



ROTATION EQUIPMENT