

SL609-OUTDOOR-HLR-RT

HANDLING

SL609-OUTDOOR-HLR-RT

HANDLING

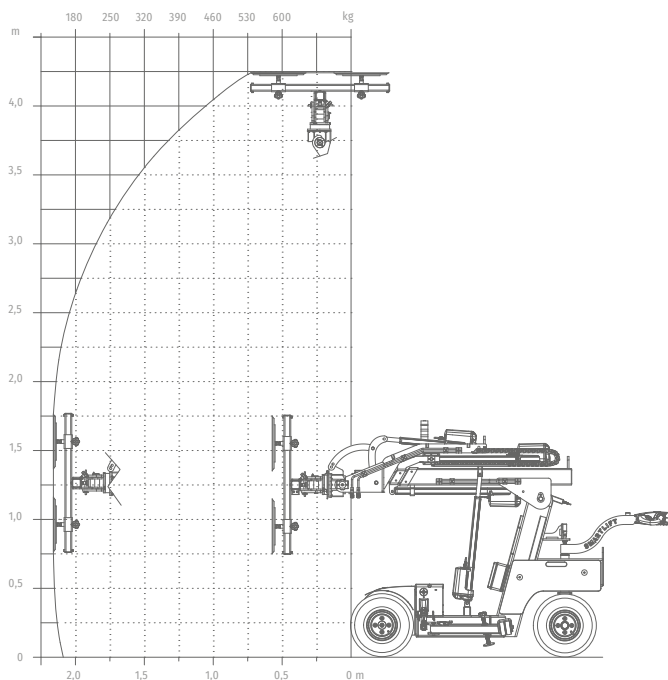

TECHNICAL DATA

DESCRIPTION	VALUE	DESCRIPTION	VALUE
Model	SL 609 HLE RT Outdoor	Front-wheel drive	1500 W AC
Lifting cap. arm in/out	600/150kg	Suction pads	4 x Ø400mm
Lifting height	4200mm	Width	830mm / 33in
Extension of arm	700+900mm	Curb weight	960kg
Tip from horizontal	40° back / 100° fwd	Class	IP 65
Side shift	100mm		
Charging voltage	230 V / 110V		
Charging time	Approx. 8 hrs		
Running period	Up to 9 hrs		

SL609-OUTDOOR-HLR-RT

