

XL1-600G

XL1-600G+4AL-XL1

WORK SERIES

XL1-600G



300 kg



45 kg



REMOTE CONTROL



LIGHT

XL1-600G+4AL-XL1



600 kg



65 kg

ENH355	OK
	360°
	0° - 60° - 90°
	30 L/min
	OK

kW	60 W
	BATTERY CHARGE 220-240V AC 50-60 HZ
	OK - 12h. approx.
	OK

XL1-600G

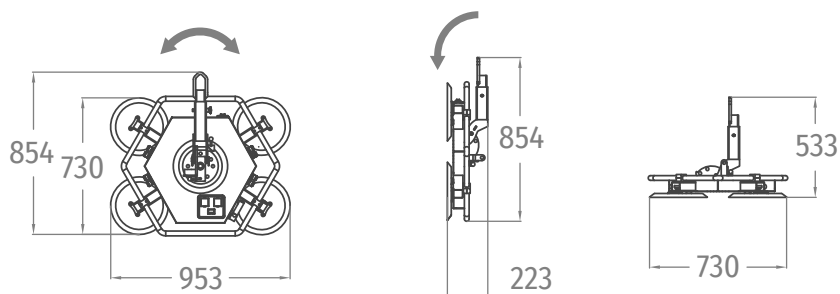

XL1-600G+4AL-XL1

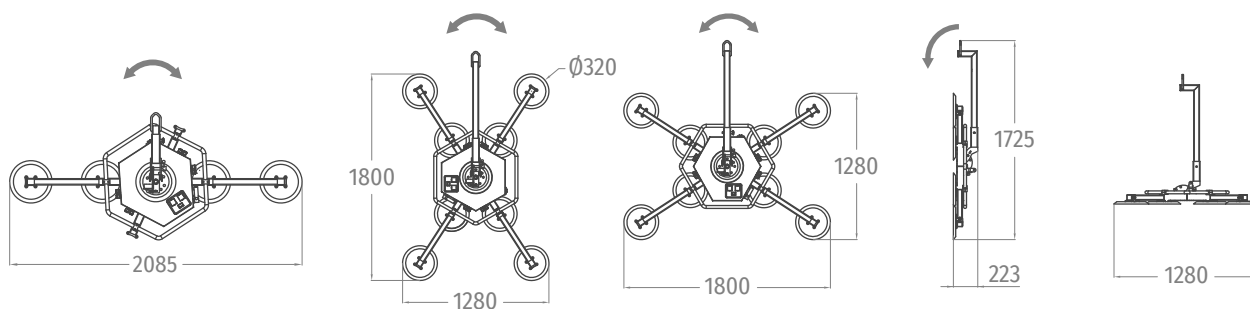

INCLUDED

- SUPPORT WITH WHEELS
- FIXED HOLDING EXTENSION 2 SIZES

OPTIONAL

- **CM-XL1** METAL BOX
- **PI-XL1** HYDRAULIC TILTING PISTON
- **MI-04A** WIRELESS REMOTE CONTROL
- **ALS-C1** AUXILIAR LIGHT
- **C150-XL1** CURVED GLASS ARM 9+9 SUCTION CUPS Ø125 (270KG)
- **C275-XL1** CURVED GLASS ARM 5+5 SUCTION CUPS Ø275 (500KG)
- **4AL-XL1**