

XL3-1000G

XL3-1000G+4

WORK SERIES

XL3-1000G



	1000 kg
	500 kg
	91 kg



XL3-1000G+4



	1000 kg
	1000 kg
	126 kg



 OK
 360°
 0° - 30° - 60° - 90°
 30 L/min

 60 W
 220-240V (50-60 Hz)
 BATTERY 12 V
 OK

XL3-1000G

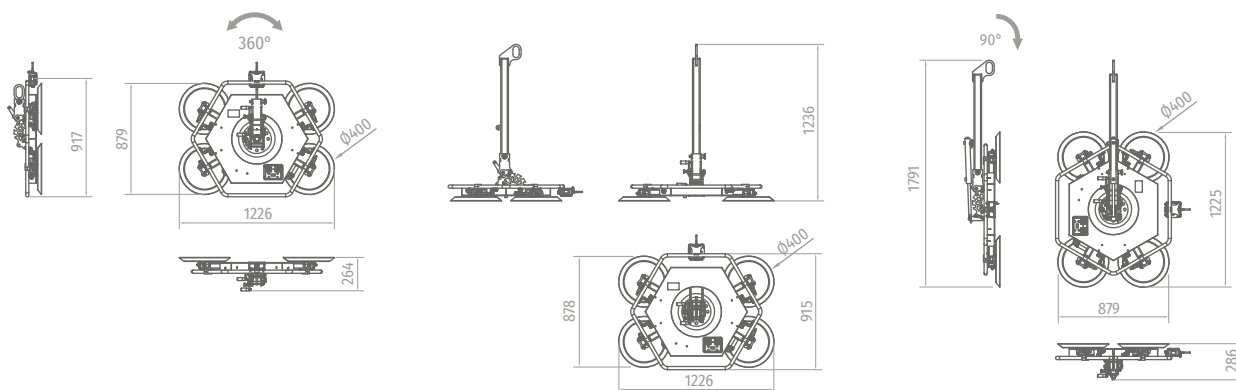

XL3-1000G+4

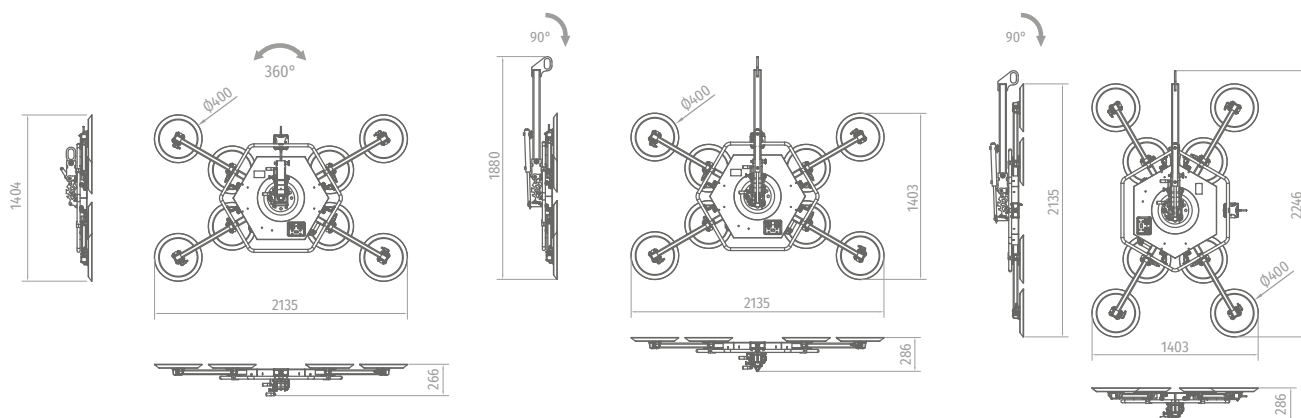

INCLUDED

- METAL BOX
- FIXED HOLDING EXTENSION 2 SIZES
- SUPPORT

OPTIONAL

- **PI-XL3** HYDRAULIC TILTING PISTON
- **MI-04A** WIRELESS REMOTE CONTROL
- **4AL-XL3** REMOVABLE EXTENSIONS WITH VACUUM CUPS